



MXT

Square Drive Tool

The MXT is the world's best-selling industrial bolting system with over one hundred thousand in use around the world. Since 1990, the signature blue housing has represented quality, durability and reliability on job sites in every major industry. From the tallest roller coasters to the world's largest bridges, the MXT has the power to get the job done.

Lock-Up Release

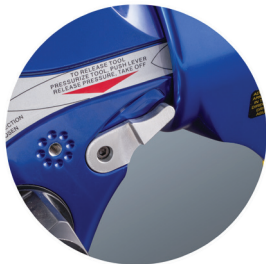

The MXT was the first tool in the industry to feature a release lever that allows you to release the tool if it locks on the application. (Also found on Avanti series)

No-Slip Ratchet



The MXT series pioneered this new system for more powerful breakout and faster tightening. The secondary pawl inside the tool prevents the ratchet from turning opposite of the direction it is being driven.

Special Alloy Option



The MXT-SA series provides the proven reliability of the MXT design with advanced materials used to increase lifespan further for extreme usage. The MXT-SA tools come with a 5 year no-questions warranty.

Technical Data

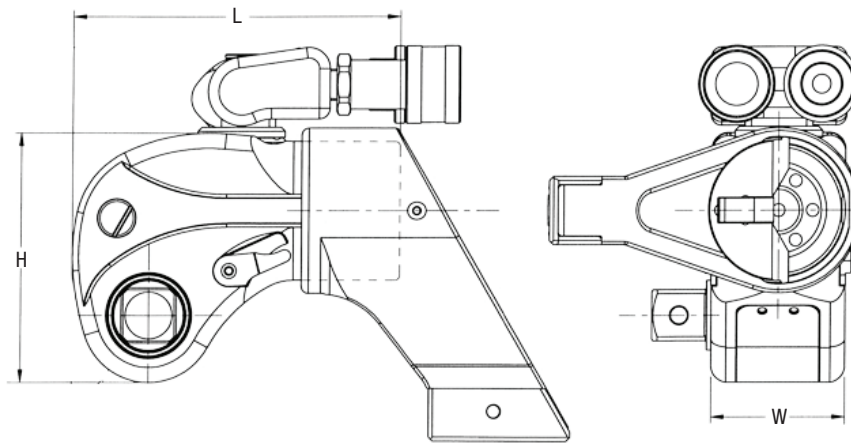

Model	H (Inch)	W (Inch)	L (Inch)	Drive (Inch)	Weight (Lbs)	Torque (ft-lbs)	
						MIN.	MAX.
MXT - .7	4.25	1.62	3.96	3/4	2.70	118	822
MXT - 1	4.90	1.97	4.88	3/4	3.95	200	1,340
MXT - 3	6.12	2.63	6.34	1	8.30	480	3,230
MXT - 5	7.22	3.16	7.61	1 1/2	14.20	835	5,590
MXT - 10	8.80	3.95	9.51	1 1/2	24.80	1,755	11,520
MXT - 15	9.67	4.38	10.55	2 1/2	36.00	2,268	15,399
MXT - 20	10.24	4.73	11.41	2 1/2	43.40	2,960	19,760
MXT - 35	12.42	5.82	14.03	2 1/2	77.45	5,400	37,100

Contact Information

333 RT. 17 North
Mahwah, NJ 07430

1-800-FOR-HYTORC
www.hytorc.com

HYTORC
Since 1968