

JETPRO S-AIR

Economically priced, the JETPRO S-AIR is an air-powered hydraulic power pack that combines industry-leading reliability with lightweight design. This 2-stage pump features a one-gallon reservoir for lightweight portability. The intuitive design of the one button control ensures improved speed and efficiency in the field. This system is part of our ATEX-approved bolting package for explosive environments.

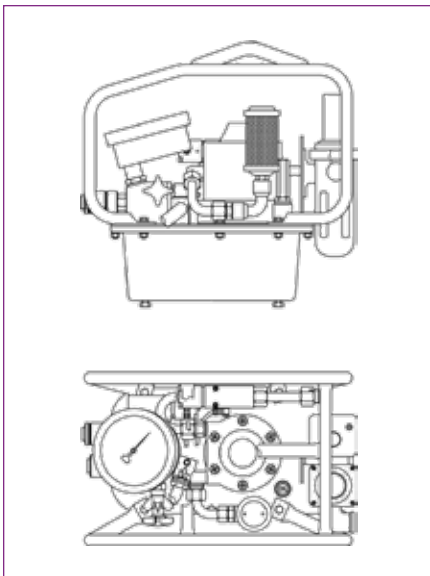

PUMP SPECIFICATIONS AND FEATURES

Air Consumption	1,900 cu.in./sec. (31 l/sec.)
Gauge	0-10 k PSI (+/-1% Accuracy)
Reservoir Capacity	0.8 gals. / 3.00 l
Stages	2
Weight	35 lbs. / 16 kg
Maximum Oil Flow Rate	370 cu. in./min. / 6 l/min.
Oil Cooler	No
Protective Caging	Yes
15' Remote Control	Yes
15' Twin Line Steel Braided Hydraulic Hose	Yes



HYTORC MISSION STATEMENT

HYTORC'S MISSION IS TO OPTIMIZE SAFETY, QUALITY AND SCHEDULE IN INDUSTRIAL BOLTING THROUGH INNOVATIVE SOLUTIONS, AND AN UNYIELDING COMMITMENT TO WORLD-CLASS CUSTOMER SERVICE.

MOBILE SERVICES



Mobile service, maintenance, and on-site training to get you and your tools back on the job faster than ever before.

WORLDWIDE SERVICE



The HYTORC Universe is made up of over 1,000 trained bolting specialists to support your bolting needs in over 100 countries.

THE HYTORC STANDARD



With over 50 years of experience focused entirely on developing the highest quality industrial bolting systems, HYTORC remains committed to higher performance and service and offers superior technology, quality, and support.

The World's Most Trusted Industrial Bolting Systems

HYTORC owns all content, copyrights, trademarks and patents in this document. © 2021 HYTORC. Any unauthorized use or distribution of any material from this document is strictly prohibited.



Headquarters:
333 Route 17 N., Mahwah, NJ 07430
+1-201-512-9500

Email:
info@hytorc.com

Phone:
1-800-FOR-HYTORC

Online:
hytorc.com