



HYTORC WASHER

The HYTORC Washer is the simplest upgrade for instant improvements in safety, speed and accuracy. This unique, patented system eliminates the need for reaction arms and other custom fixtures required to hold the tool in place. Additionally, the precision machined surface reduces variation in bolt load across the flange for improved accuracy and loosening prevention.

SAFETY



The HYTORC Washer eliminates the need for reaction arms, which are the most common cause of injury on bolting jobs. The unique design of the washer allows the double layered safety socket to react on the washer itself, while turning the nut.

SPEED



The HYTORC Washer removes the complicated setup associated with other bolting systems and makes the bolting process more intuitive for improved job times. Our patented knurling ensures against bolt rotation during any operation.

SYSTEM COMPARISON

TORQUE WRENCH USED WITH BACKUP WRENCH

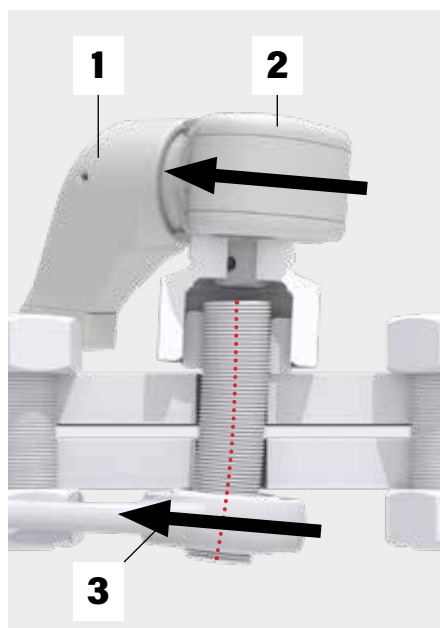

Torque wrench and backup wrench rotate in same direction.

- 1) Reaction fixture
- 2) Torque wrench
- 3) Backup wrench
- ← Same direction of rotation of torque wrench and backup wrench
- ⋯ Yielded bolt center axis

DOUBLE SOCKET DRIVE USED WITH HYTORC WASHER

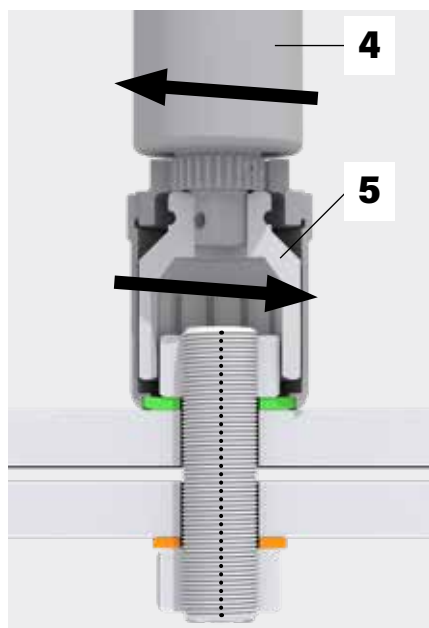

The HYTORC Washer grips surface while the backup washer keeps the bolt in place and square with the surface.

- 4) Torque wrench
- 5) Double socket drive
- HYTORC Washer
- Backup washer
- ← Direction of rotation of torque wrench
- Direction of rotation of double socket drive
- ⋯ Uncompromised bolt center axis

UNNECESSARY JOB CONDITIONS



Pinch hazards and more personnel; damaging side loads; bending forces; shorter lifespan of nuts and bolts.

OPTIMAL JOB CONDITIONS



No pinch hazards; intuitive operation; less personnel; no damaging side loads or bending forces; nuts and bolts can be reused.

RE-MACHINED/DAMAGED FLANGE SURFACE

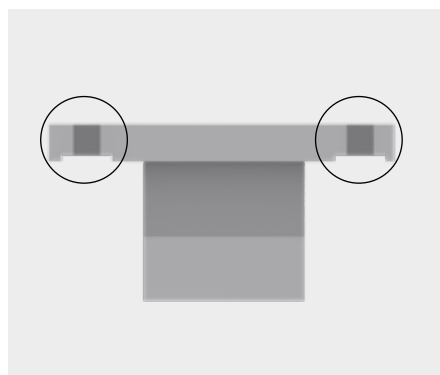

Repeated tightening and loosening of nuts and bolts cause extended wear and damage (re-machining) to flange surfaces.

FLANGE PROTECTION

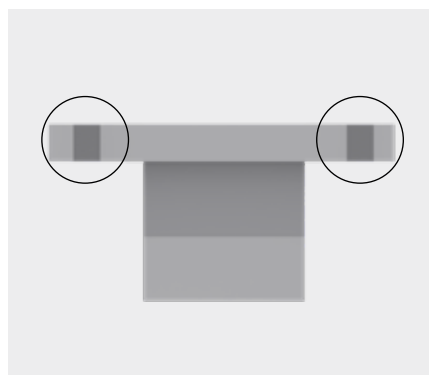

The HYTORC Washer protects the flange surface, eliminating the need for expensive flange resurfacing processes; extended flange longevity.



Headquarters:
333 Route 17 N., Mahwah, NJ 07430
+1-201-512-9500

Email:
info@hytorc.com

Phone:
1-800-FOR-HYTORC

Online:
hytorc.com