

HYTORC NUT

For critical applications requiring the highest level of bolt load control, the patented HYTORC Nut system provides industry-leading joint integrity. This three-piece fastener applies pure tension to the bolt to prevent thread damage and ensure bolt load accuracy. The HYTORC Nut is available in a variety of materials to suit all applications, from extreme temperatures to harsh climates.

CALIBRATED LOAD ACCURACY



No other bolting system provides the same level of repeatable accuracy, ensuring even bolt load to eliminate joint failure and unintentional nut loosening.

BOLT THREAD PROTECTION



The HYTORC Nut is the only fastener that can guarantee the elimination of galled or damaged threads on installation and removal. These fasteners have been installed on various high temperature applications for ten years and longer, and were removed without damage to the bolts, providing tremendous savings by eliminating the need for bolt replacement.

SYSTEM COMPARISON

TORQUE WRENCH USED WITH BACKUP WRENCH

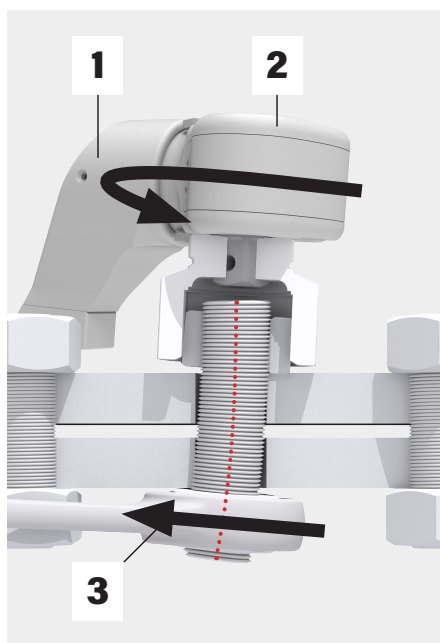

Torque wrench and backup wrench rotate in same direction.

- 1) Reaction fixture
- 2) Torque wrench
- 3) Backup wrench
- ↺ Incorrect angle and direction of rotation of torque wrench
- ← Incorrect angle and direction of rotation of backup wrench
- ⋮ Yielded bolt center axis

HYTORC NUT

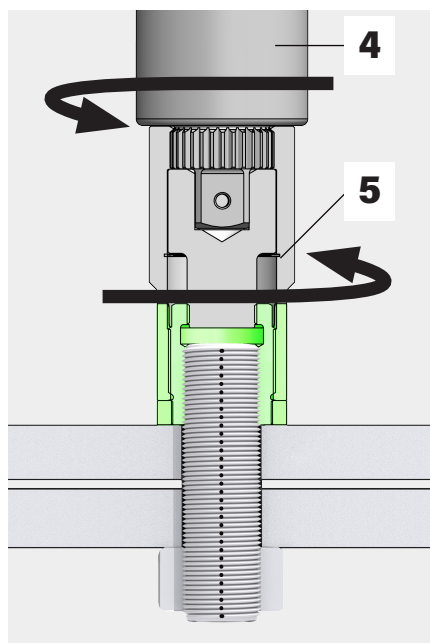

The HYTORC Nut ensures a level bolting operation.

- 4) Torque wrench
- 5) HYTORC Nut driver
- HYTORC Nut
- ↺ Direction of rotation of torque wrench
- ↻ Direction of rotation of nut driver
- ⋮ Uncompromised bolt center axis

STANDARD BOLT LOAD SCATTER

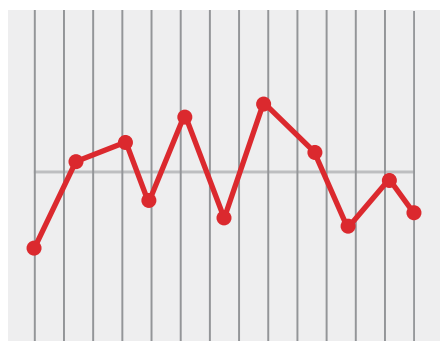

The coefficient of friction negatively affects the bolt load.

OPTIMIZED BOLT LOAD SCATTER

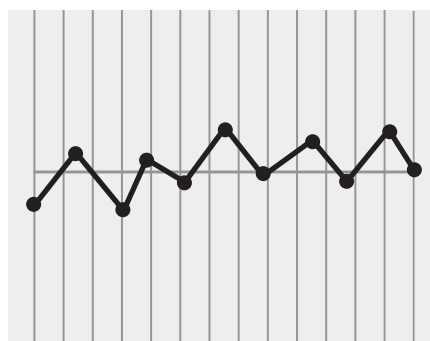

The HYTORC Nut significantly reduces the scatter of the bolt load by half.

POTENTIAL FOR LEAKAGE

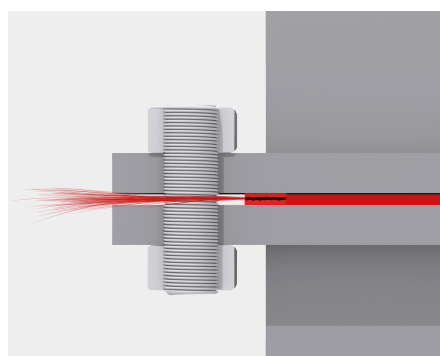

Repeated tightening and loosening of nuts and bolts causes extended wear and damage (re-machining) to flange surfaces.

SEAL INTEGRITY

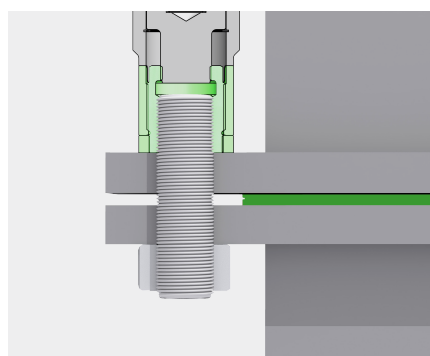

Even and accurate bolt load applies even pressure to the flange, improving joint integrity and reducing the chance of leakage; extended flange longevity.

HYTORC owns all content, copyrights, trademarks and patents in this document. © 2020 HYTORC. Any unauthorized use or distribution of any material from this document is strictly prohibited.



Headquarters:
333 Route 17 N., Mahwah, NJ 07430
+1-201-512-9500

Email:
info@hytorc.com

Phone:
1-800-FOR-HYTORC

Online:
hytorc.com