



# TSR+ AUTO RETURN TENSIONER

## Features

### INTERCHANGEABLE

TSR+ load cells have exactly the same overall dimensions and hydraulic specification as the existing TSR load cells. This ensures interchangeability and ease of customer upgrades to the new range.

### DURABLE

Operational performance does not degrade during the life of the tool. TSR+ completed more than 10,000 full pressure/stroke cycles during in-house testing.

### INCREASED SAFETY

TSR+ load cells have a relief valve to prevent accidental overstroke of the tool. This safety mechanism prevents seal blow outs and the users exposure to ejected oil.

### PREMIUM SURFACE TREATMENT

All load cells have unique surface finish which provides a long lasting finish against harsh environments.

### IMPROVED SEAL TECHNOLOGY

Latest design eases seal changeouts and enhances general performance throughout high cycle usage.

### OPTIONS

- Twin port hydraulic connections
- Oversized Threads
- Geat Drive nut rotation
- Swivel connectors
- Special designs

The all new TSR+ Auto Return Tensioner range has been designed to ensure fast, simple, safe and reliable operation. With a focus on productivity and a reduction in downtime we have implemented state of the art materials and technology resulting in significant time saving during operation.

## TECHNICAL AND DIMENSIONAL SPECIFICATION

<b>Tensioner Design</b>	Single acting cylinder, auto return
<b>Maximum Operating Pressure</b>	1500 bar (21750 psi)
<b>Stroke</b>	10mm (0.375 inches) except TSR+ O - 8mm (0.315 inches)
<b>Hydraulic Oil Type</b>	ISO 32 or equivalent

(Continued on back)

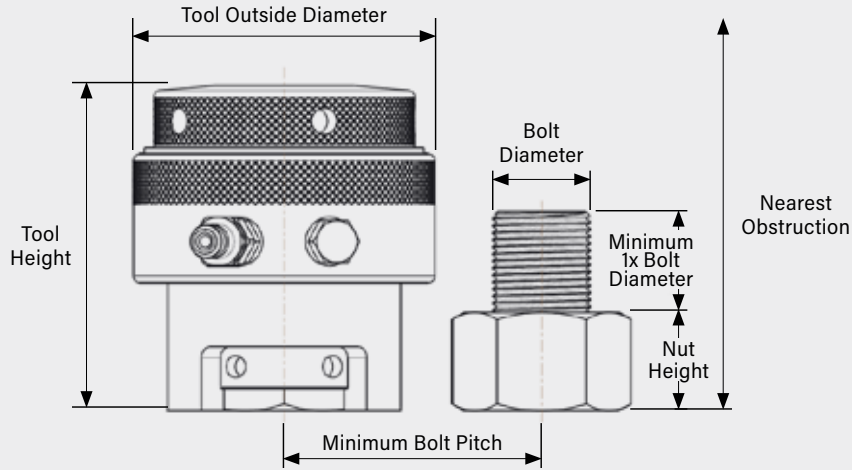

TOOL NUMBER	BOLT DIAMETER		HYDRAULIC AREA mm <sup>2</sup>	MAXIMUM LOAD		TOOL OUTSIDE DIAMETER		TOOL HEIGHT		DISTANCE TO NEAREST OBSTRUCTION		TOTAL TOOL WEIGHT		LOAD CELL WEIGHT	
	in.	mm		lbf	kN	in.	mm	in.	mm	in.	mm	lbs	kg	lbs	kg
TSR+ 0*	3/4	M20	1,070	35,970	160	2.60	66	4.69	119	5.59	142	3.1	1.4	2.2	1
		M22						4.69	119	5.67	144				
TSR+ 1	1 1-1/8	M24	1,870	62,950	280	3.43	87	5.71	145	6.89	175	8.8	4	5.3	2.4
		M27						5.71	145	7.01	178				
								5.83	148	7.01	178				
TSR+ 2	1 1-1/8 1-1/4 1-3/8	M24	3,000	101,160	450	4.06	103	5.71	145	6.89	175	12.8	5.8	7.3	3.3
		M27						5.83	148	7.01	178				
		M30						5.94	151	7.24	184				
		M33						4.84	123	7.48	190				
		M36						6.06	154	7.72	196				
TSR+ 3	1-1/4 1-3/8 1-1/2 1-5/8	M33	4,400	148,370	660	4.65	118	6.02	153	7.56	192	17	7.7	9.3	4.2
		M36						6.14	156	7.80	198				
		M39						6.28	159.5	8.03	204				
		M42						6.42	163	8.31	211				
TSR+ 4	1-1/2 1-5/8 1-3/4 1-7/8 2	M39	6,670	224,810	1,000	5.55	141	6.65	169	8.35	212	26.5	12	13.4	6.1
		M42						6.77	172	8.58	218				
		M45						6.89	175	8.86	225				
		M48						7.01	178	9.09	231				
								7.13	181	9.09	231				
TSR+ 5	2 2-1/4 2-1/2 2-3/4	M52	10,000	337,210	1,500	6.93	176	7.48	190	9.76	248	42.8	19.4	21	9.5
		M56						7.74	196.5	10.16	258				
		M60						7.99	203	10.31	262				
		M64						8.23	209	10.75	273				
		M68						8.23	209	11.14	283				
TSR+ 6	2-3/4 3 3-1/4 3-1/2	M72	16,670	562,020	2,500	8.62	219	8.66	220	11.69	297	76	34.5	32.4	14.7
		M76						8.82	224	12.13	308				
		M80						9.17	233	12.28	312				
		M85						9.41	239	12.72	323				
		M90						9.41	239	13.15	334				
TSR+ 7	3-1/2 3-3/4 4	M90	21,340	719,390	3,200	9.92	252	9.69	246	13.43	341	103.6	47	42.8	19.4
		M95						9.92	252	13.62	346				
								10.20	259	14.02	356				
								10.20	259	14.02	356				

\*TSR+ 0 is not an auto return tensioner.

HYTORC owns all content, copyrights, trademarks and patents in this document. © 2021 HYTORC. Any unauthorized use or distribution of any material from this document is strictly prohibited.



**Headquarters:**  
333 Route 17 N., Mahwah, NJ 07430  
+1-201-512-9500

**Email:**  
info@hytorc.com

**Phone:**  
1-800-FOR-HYTORC

**Online:**  
hytorc.com