



QUICK SPECS

WEIGHT

71.65 lbs / 32.5 kg

POWER

1.5 kW / 2.1 HP

RESERVOIR CAPACITY

2 Gal / 7.5L

HY-T Series
Electric Tensioning Pump

The **HY-T tensioning pump** helps you get the job done faster, with high-speed performance that keeps your operation moving. Designed for straightforward setup and operation, it minimizes downtime and maximizes productivity across a wide range of bolting applications. Built to withstand tough jobsite conditions, the HY-T is engineered to keep working as hard as you do. This advanced HYTORC tensioning pump delivers high-speed performance to keep your projects moving efficiently. It now features a superior pressure gauge that provides clearer, more accurate readings at a glance, and an optional digital pressure remote gives you even more control when precision matters most.

- **RAPID PRESSURE BUILD-UP AND RELEASE**
- **USER-FRIENDLY DESIGN**
- **DURABILITY**
- **RELIABILITY**

FULL SPECIFICATIONS

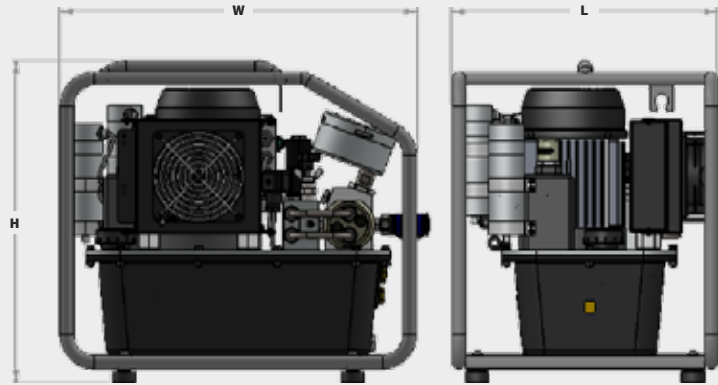
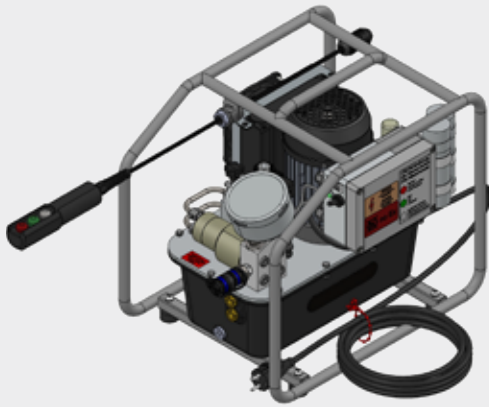

LEGEND: L = LENGTH H = HEIGHT W = WIDTH

SPECIFICATIONS AND FEATURES

Length	18.4 in. / 468 mm	
Height	16.5 in. / 419 mm	
Width	13.7 in. / 348 mm	
Maximum Output Pressure	21750 psi / 1500 bar	
Pressure Regulation Valve	Manually adjustable pressure regulation valve	
Power	115V : 1.6kW / 2.2HP 230V: 1.5kW / 2.0HP	
Noise Level	LPA: 74dB / LWA: 92 dB	
Reservoir Capacity	2 Gal / 7.6 L	
Fillable amount of Oil	1.37 US Gal / 5.2 L	
Weight (without oil)	71.6 lbs / 32.5 kg	
Weight (with oil)	81.6 lbs. / 37 kg	
Remote Control Length*	Standard remote:	5m/~15ft
	Digital Pressure Reading remote:	5m/~15ft
Digital pressure readout	Optional upgrade	
Oil Cooler	Yes	
Port connection	1 port - CEJN 116	
Pump Capacity	@ 0 - 7250 psi (0-500 bar) @ 7250 - 21755 psi (500 bar - 1500 bar)	Max 0.66 Gal/min (2.5L/min) to 0.066 Gal/min (0.25L/min) ~0.066 Gal/min (0.25L/min)
Grid Power Options	115 V at 50/60Hz 230 V at 50/60Hz	

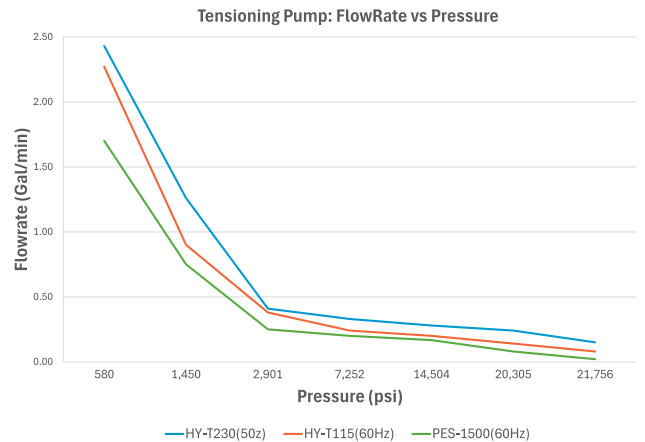

* Various other lengths available upon request

PART NUMBER	DESCRIPTION
HY-T115-2-M	115v 50/60 Hz Electric Tensioner Pump, 1500 Bar, Manual, 2 Gallon Reservoir
HY-T230-2-M	230v 50/60 Hz Electric Tensioner Pump, 1500 Bar, Manual, 2 Gallon Reservoir
HY-T115-2-PR	115v 50/60 Hz Electric Tensioner Pump, 1500 Bar, 2 Gallon Reservoir, Pressure Reading
HY-T230-2-PR	230v 50/60 Hz Electric Tensioner Pump, 1500 Bar, 2 Gallon Reservoir, Pressure Reading

HYTORC owns all content, copyrights, trademarks and patents in this document. © 2025 HYTORC. Any unauthorized use or distribution of any material from this document is strictly prohibited.

Headquarters:
333 Route 17 N., Mahwah, NJ 07430
+1-201-512-9500

Contact:
1-800-FOR-HYTORC
info@hytorc.com

Online:
hytorc.com