



HYTORC[®]

DIVISION UNEX CORPORATION

333 STATE RTE. 17 NORTH
MAHWAH, NJ 07430-9895
Tel: (201) 512-9500
Fax: (201) 512-9615

Form No. 108136

Parts List for:

JET-115
JET-230

MODEL B
ELECTRIC HYDRAULIC PUMP
Max. Capacity: 10,000 PSI

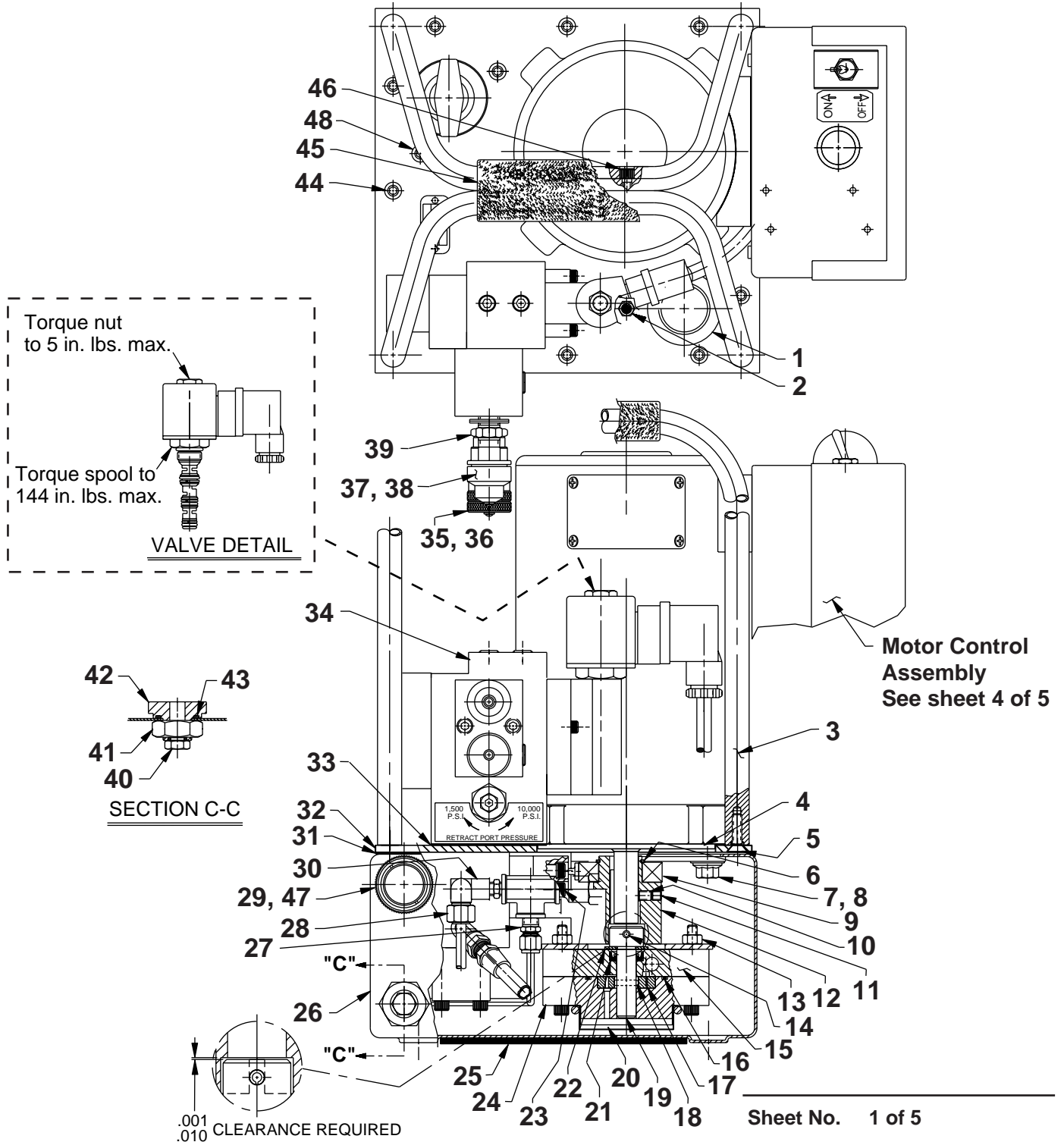

Sheet No. 1 of 5

Rev. 3

Date: 12 Feb. 2001

Parts List, Form No. 108136, Back sheet 1 of 5

Item No.	Part No.	No. Req'd	Description	Item No.	Part No.	No. Req'd	Description
1	*350925	1	Filler Cap	24	64580	1	Lower Gerotor Housing
2	251599	1	Breather Filter Vent	25	420948	1	Rubber Pad (Apply 3M adhesive #08031 to reservoir and pad.)
3	66408BK2	2	Roll Cage Frame	26	65126BK2	1	Reservoir
4	351060	1	Motor Base Gasket	27	14844	1	Straight Fitting
5	11529	4	Screw (1/4-20 UNC x 1" Lg.; Apply Loctite #242)	28	15052	1	90° Elbow Fitting
6	209798	1	Retaining Ring	29	17586	1	Sight Gauge
7	213663	4	Cap Screw (3/8-16 UNC X 1" Lg.; Torque to 230/250 in. lbs.)	30	18969	1	Pipe Tee
8	10258	4	Washer (For 3/8 bolt)	31	*58779	1	Gasket
9	209805	1	Ball Bearing	32	66039BK2	1	Cover Plate
10	10136	1	Set Screw (1/4-20 UNC x 1/4 Lg.; Torque to 60/80 in. lbs.)	33	351095	1	Valve Gasket
11	10519	1	Set Screw (1/4-20 UNC X 3/8 Lg.; Torque to 60/80 in. lbs.)	34	421293	1	Valve Assembly (See Form No. 105549)
12	420840	1	Eccentric	35	*251797	1	Coupler
13	10199	2	Hex Nut (1/4-20 UNC)	36	252068	1	Dust Cap
14	12298	1	Roll Pin (3/16 dia. x 1-1/2" Lg.)	37	*251798	1	Coupler
15	65137	1	Upper Gerotor Housing	38	252069	1	Dust Cap
16	10922	1	O-ring (2-1/8" X 1-15/16" X 3/32)	39	10672	1	Straight Fitting
17	304826	1	Gerotor	40	17147	1	Plug Fitting
18	209794	1	Gerotor Drive Pin	41	10396	1	Jam Nut (3/4-16 UNF)
19	350940	1	Gerotor Shaft	42	351000	1	Drain
20	21846	1	Filter Support	43	14725	1	O-ring (1-1/8" x 15/16 x 3/32)
21	304830	1	Oil Seal	44	10177	12	Screw (1/4-20 x 3/4 Lg.)
22	12595	1	Washer (1-1/8" X 1/2 X .077 Thk.)	45	251600	1	Handle Grip
23	10022	4	Screw (1/4-20 UNC X 1-1/2" Lg.; Torque to 180/200 in. lbs.)	46	10008	2	Cap Screw (1/4-20 UNC x 3/4 Lg.)
				47	253300	1	Seal Washer
				48	15911	3	Screw (1/4-20 x 5/8)

Part numbers marked with an asterisk (*) are contained in Repair Kit No. 090205.

HYDRAULIC SCHEMATIC

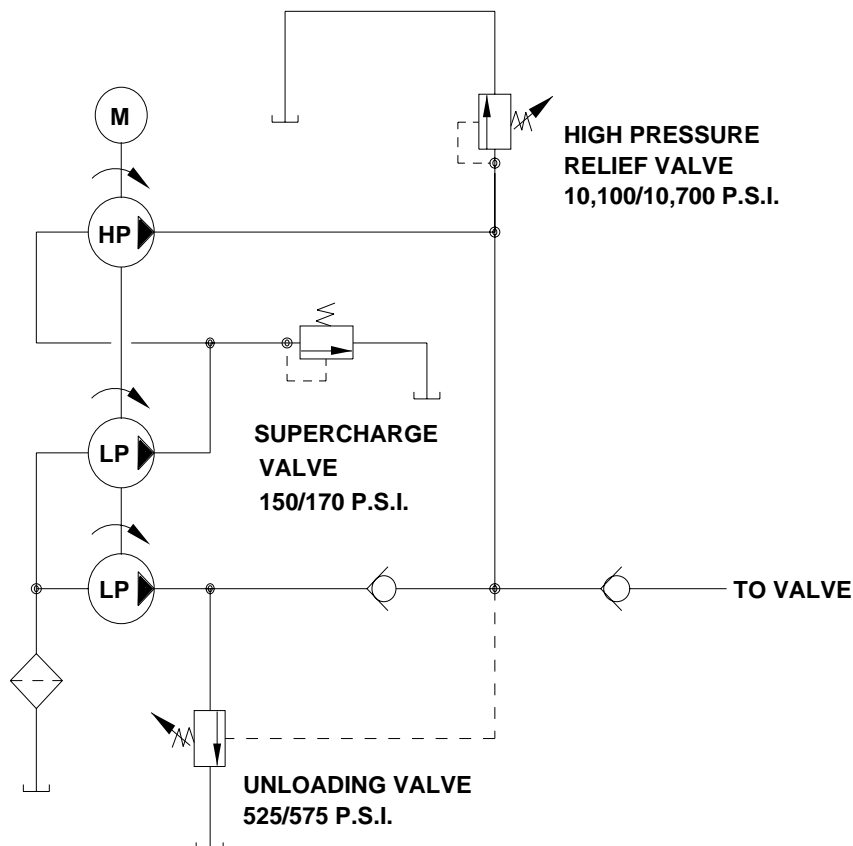

BOTTOM VIEW

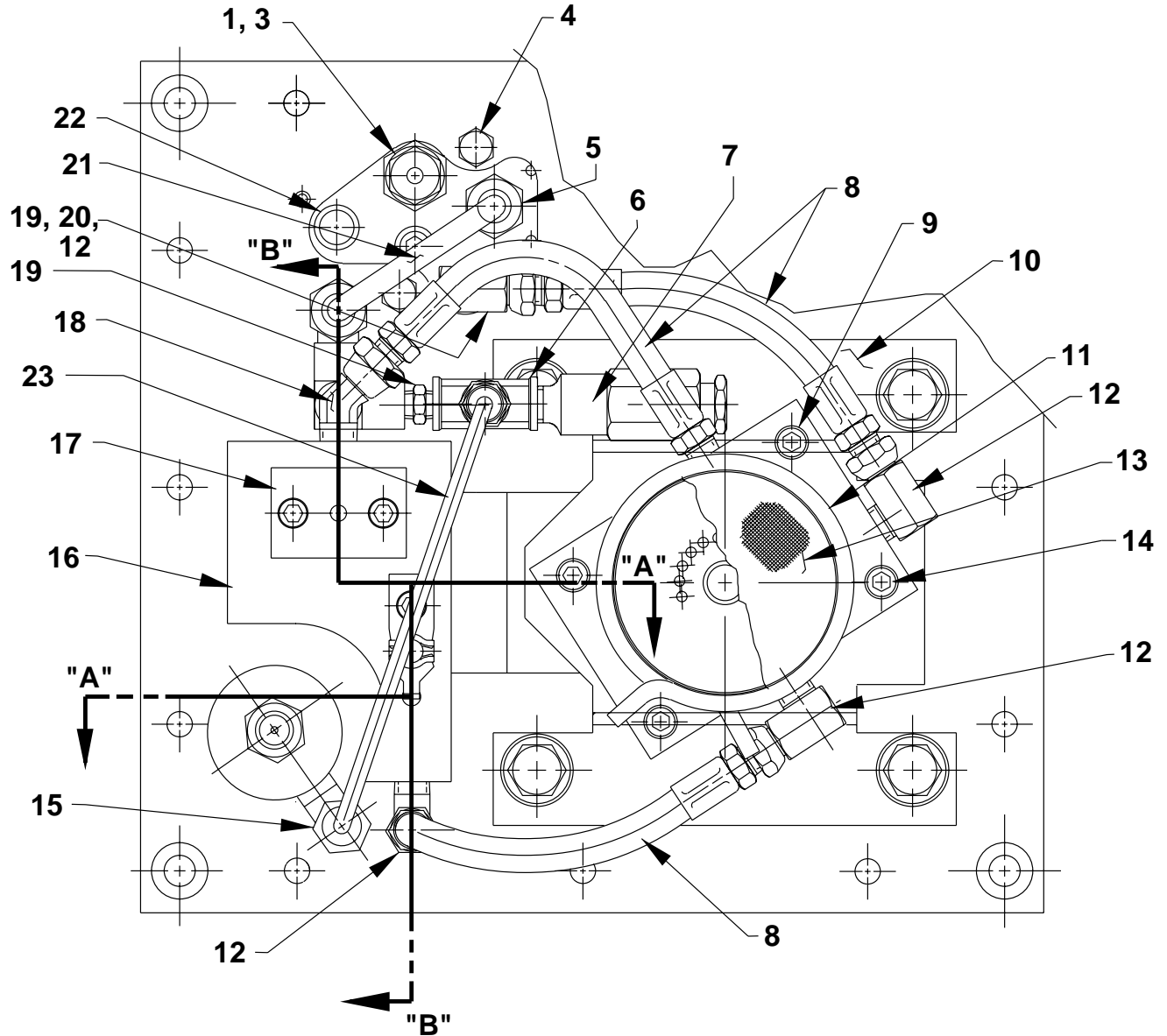

Item No.	Part No.	No. Req'd	Description
1	251751	1	Pipe Fitting
3	*21278-15	1	Relief Valve Assembly (Set at 1,500/1,700 PSI)
4	12825	3	Cap Screw (1/4-20 UNC X 5/8 Lg.)
5	205793	1	Connector
6	215033	1	Elbow Fitting
7	*21278	1	Relief Valve Assembly (Set at 10,100/10,700 PSI)
8	304819	3	Hose Assembly
9	10022	2	Screw (1/4-20 UNC X 1-1/2" Lg.; Torque to 60/80 in. lbs.)
10	58481	1	Gerotor Housing Bracket
11	11461	1	Hose Clamp

Item No.	Part No.	No. Req'd	Description
12	14440	4	90° Elbow Fitting
13	*21608	1	Filter
14	10890	2	Cap Screw (1/4-20 X 2" Lg.; Torque to 60/80 in. lbs.)
15	16177	1	90° Elbow Fitting
16	65128	1	Check Body
17	350930	1	Retaining Block
18	251800	1	Elbow Fitting
19	11421	2	Pipe Nipple
20	18841	1	Pipe Connector
21	252091	1	Oil Line Tube
22	250630	1	Drain Tube
23	252149	1	Oil Line Tube

Part numbers marked with an asterisk (*) are contained in Repair Kit No. 090205.

SECTION A-A

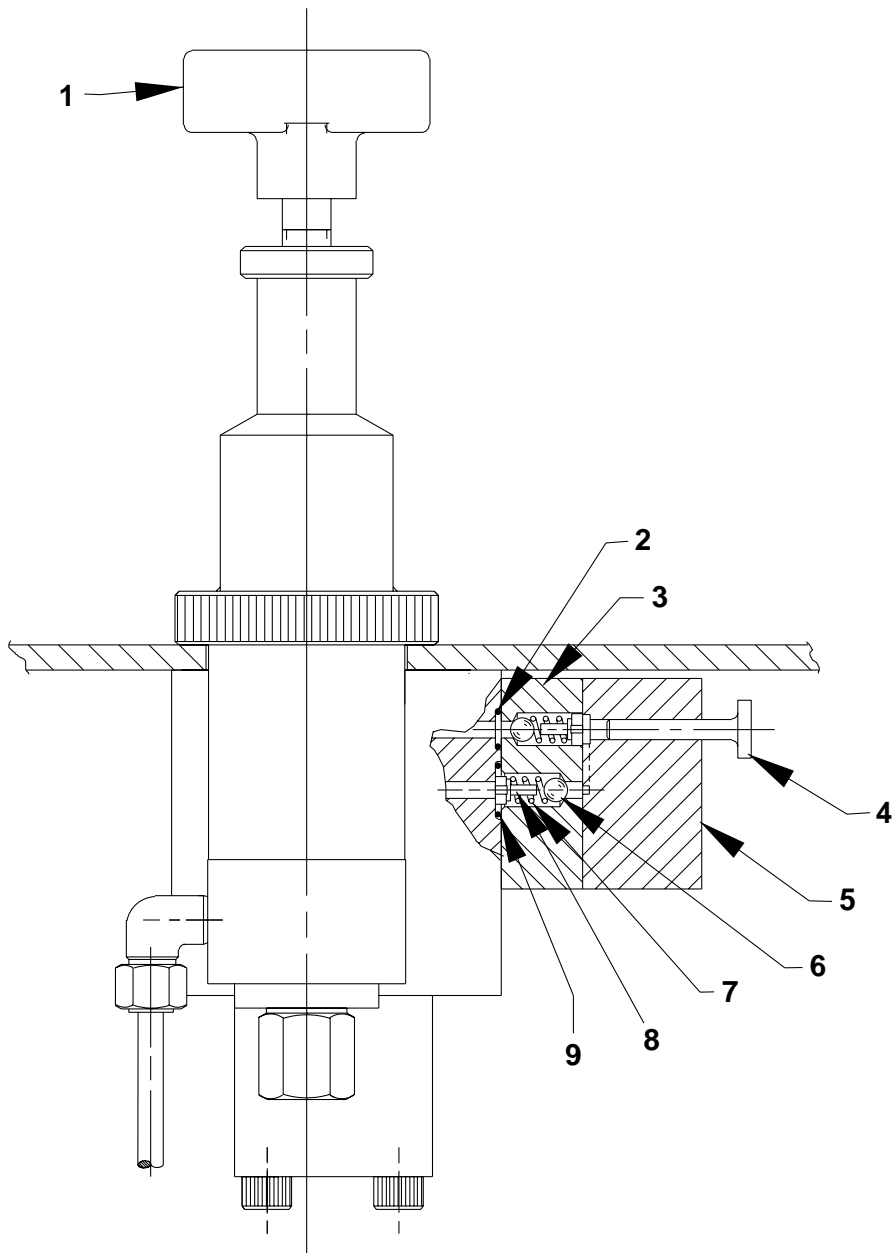

Item No.	Part No.	No. Req'd	Description
1	420963	1	External Relief Valve (See Form No. 105550)
2	10265	1	O-ring (5/16 X 3/16 X 1/16)
3	45559	1	Block
4	305526	1	High Pressure Piston
5	45866	1	Block
6	12223	2	Ball (3/16 Dia.)
7	10445	2	Compression Spring (5/32 O.D. X 3/4 Lg.)
8	24549	2	Ball Guide
9	14763	1	O-ring (7/16 X 5/16 X 1/16)

SECTION B-B

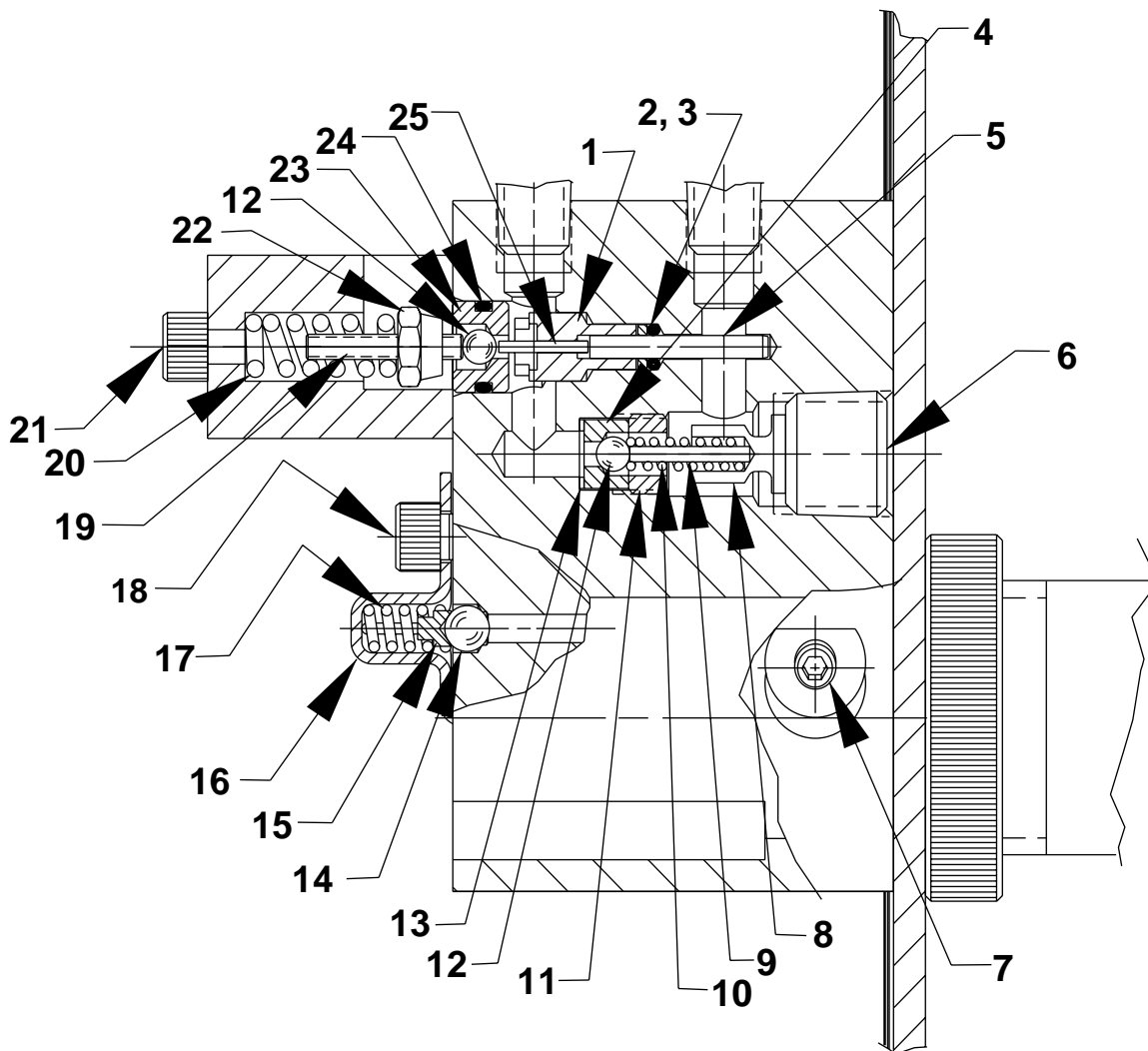

Item No.	Part No.	No. Req'd	Description
1	251068	1	Guide
2	17797	1	O-ring (1/4 X 1/8 X 1/16)
3	214992	1	Backup Ring
4	209787	1	Replaceable Seat
5	16471	1	Pin (Taper on pin should be away from guide [Item #1].)
6	14972	1	Pipe Plug (1/4 NPTF)
7	15130	1	Plug (1/16 NPTF)
8	202681	1	Ball Stop
9	10895	1	Roll Pin (.13 X .75)
10	250227	1	Compression Spring (3/16 O.D. X 3/8 Lg.)
11	209797	1	Hollow Lock Screw (7/16-20 UNF-3A; Torque to 110/130 in. lbs.)
12	12223	2	Ball (3/16 Dia.)
13	10442	1	Washer (3/8 X 1/4 X 1/32)

Item No.	Part No.	No. Req'd	Description
14	10374	1	Steel Ball (7/32 Dia.)
15	200796	1	Ball & Spring Adapter
16	350577	1	Spring Retainer
17	15691	1	Compression Spring (1/4 O.D. X 5/8 Lg.)
18	10002	1	Cap Screw (1/4-20 UNC X 3/8 Lg.; Torque 60/80 in. lbs.)
19	251067	1	Set Screw (Unloading valve; #10-24 UNC x 1" Lg.)
20	14484	1	Compression Spring (3/8 O.D. X 1" Lg.)
21	10854	2	Cap Screw (1/4-20UNC X 1-3/4" Lg.; Torque to 60/80 in. lbs.)
22	207405	1	Locknut
23	251065	1	Replaceable Seat
24	10268	1	O-ring (1/2 X 3/8 X 1/16)
25	251611	1	Dowel Pin

MOTOR AND CONTROL BOX

* PROGRESSIVE REMOTE CONTROL SWITCH.
 POSITION 1 (OFF): MOTOR OFF, SOLENOID OFF.
 POSITION 2 (RET.): MOTOR ON
 POSITION 3 (ADV.): MOTOR ON, SOLENOID "A"
 ON (MOMENTARY).
 MOTOR STAYS ON IN POSITIONS 2 AND 3.

DETAIL "Y"

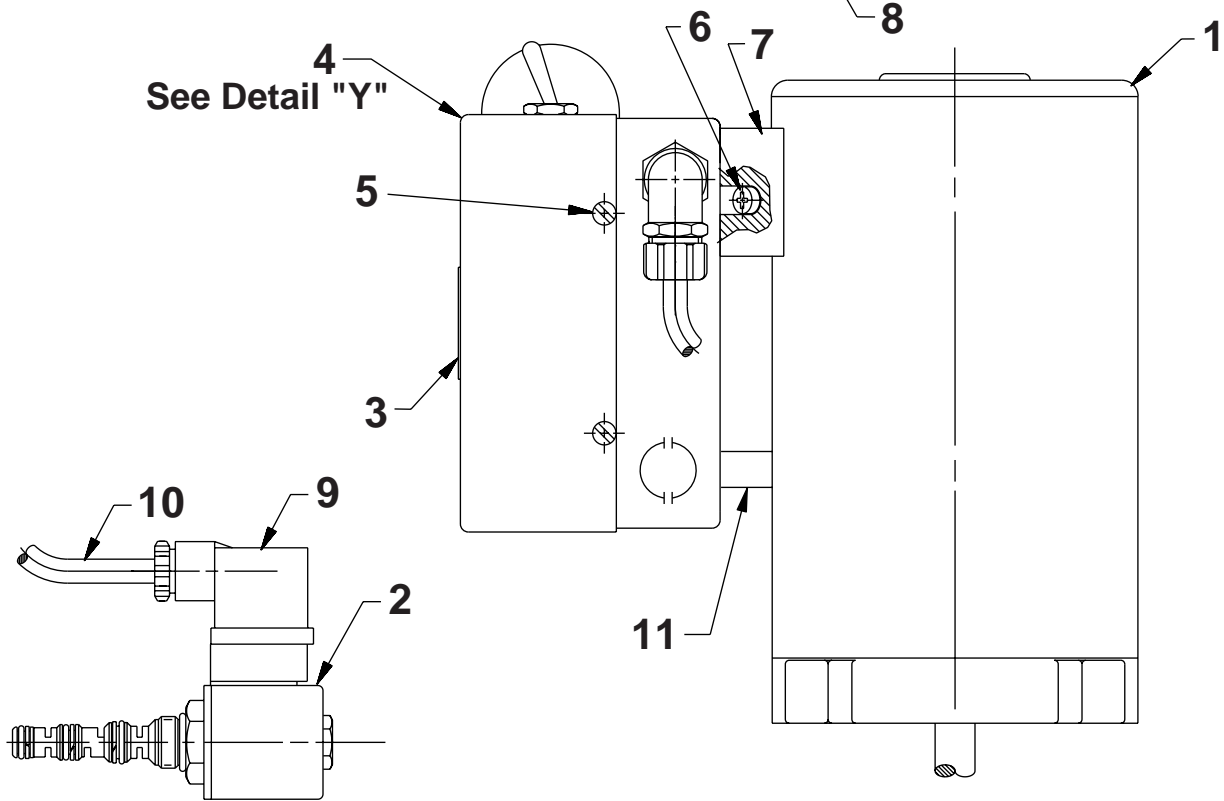
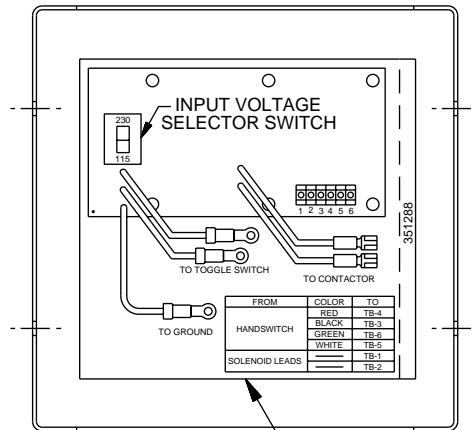

Item No.	Part No.	No. Req'd	Description
1	*422005BK2	1	Electric Motor (For JET-115)
	**422006BK2	1	Electric Motor (For JET-230)
2	351843	1	Solenoid Valve (For JET-115)
	351844	1	Solenoid Valve (For JET-230)
3	200188	1	Warning Decal
4	43126BK2	1	Control Box Cover
5	14812	4	Tap Screw (#8-18 X 3/8 Lg.)

Item No.	Part No.	No. Req'd	Description
6	12316	2	Screw (10-24 x 1/2 Lg.)
7	420962	1	Mounting Adapter
8	351513	1	Decal, Label Motor Control
9	253405	1	Connector
10	11423	1.5'	Cable (18/2 SJTO)
11	253670	1	Spacer

* NOTE: For replacement brushes, order (2) #252958.

** NOTE: For replacement brushes, order (2) #252961.

MOTOR CONTROL ASSEMBLY

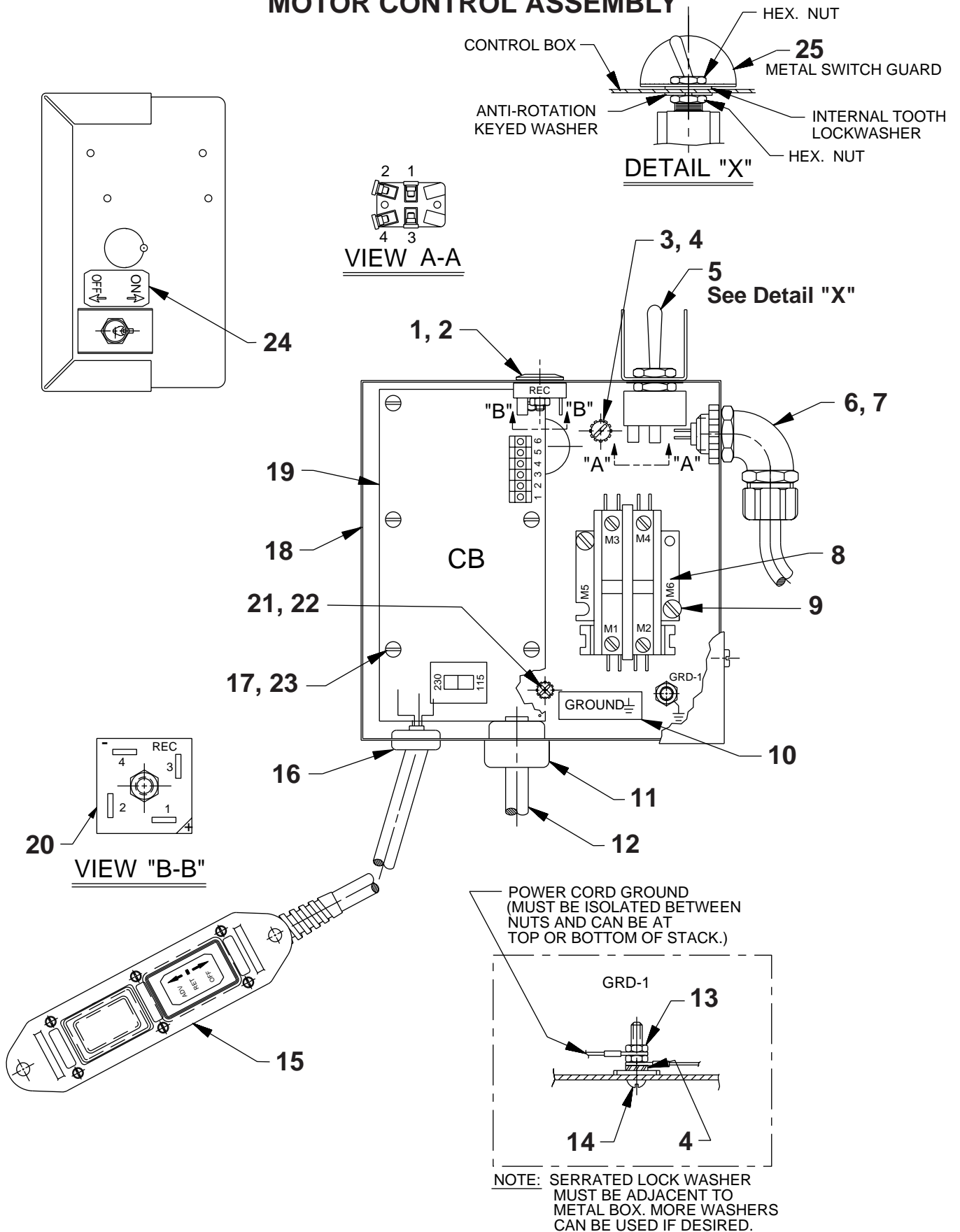

Parts List, Form No. 108136, Back sheet 4 of 5

Item No.	Part No.	No. Req'd	Description
1	216669	1	Plug
2	11010	1	Nut (#10-32)
3	12909	2	Slotted Screw (#10-32 UNF X 1/4 Lg.)
4	11108	3	Lockwasher (#10 External Tooth)
5	12958	1	Toggle Switch
6	13529	1	Cord Grip
7	11362	1	Conduit Locknut
8	420718-2	1	Contactora (For JET-230)
	420718-1	1	Contactora (For JET-115)
9	10166	2	Machine Screw (#10-24 UNC X 1/2 Lg.)
10	205189	1	Ground Decal
11	210112	1	Strain Relief Bushing
12	25229	1	Cord Set (For JET-115)
	308752	8 ft.	Electrical Cable (For JET-230)
13	10197	2	Nut (#10-24 UNC)
14	11856	1	Machine Screw (#10-24 X 1" Lg.)
15	351160	1	Hand Switch Assembly (See sheet 5 of 5)
16	15993	1	Strain Relief Bushing
17	10162	4	Machine Screw (8-32 x 1" Lg.)
18	51218BK2	1	Electrical Control Box
19	421477	1	Circuit Board (Note: Set input voltage selector switch to 115 v. position for JET-115; set input voltage selector switch to 220 v. position for JET-230.)
20	251050	1	Rectifier
21	253671	1	Screw (8-32 x 1)
22	11388	1	External Tooth Washer (.37 x .17)
23	10196	4	Hex Nut (8-32)
24	205409	1	On/Off Label Decal
25	352061	1	Metal Switch Guard

Note: Shaded areas reflect last revision(s) made to this form.

REMOTE HAND SWITCH ASSEMBLY

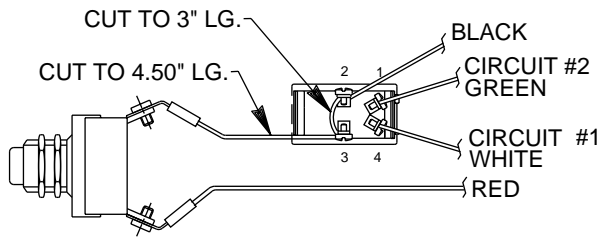
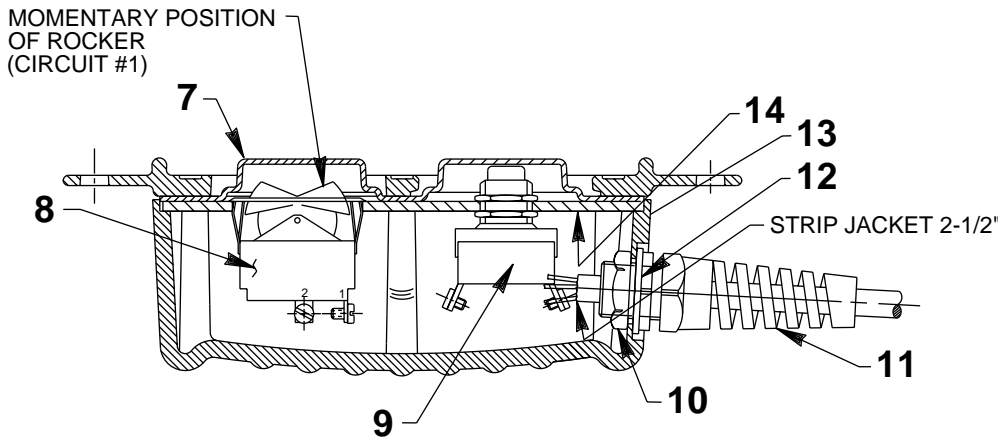
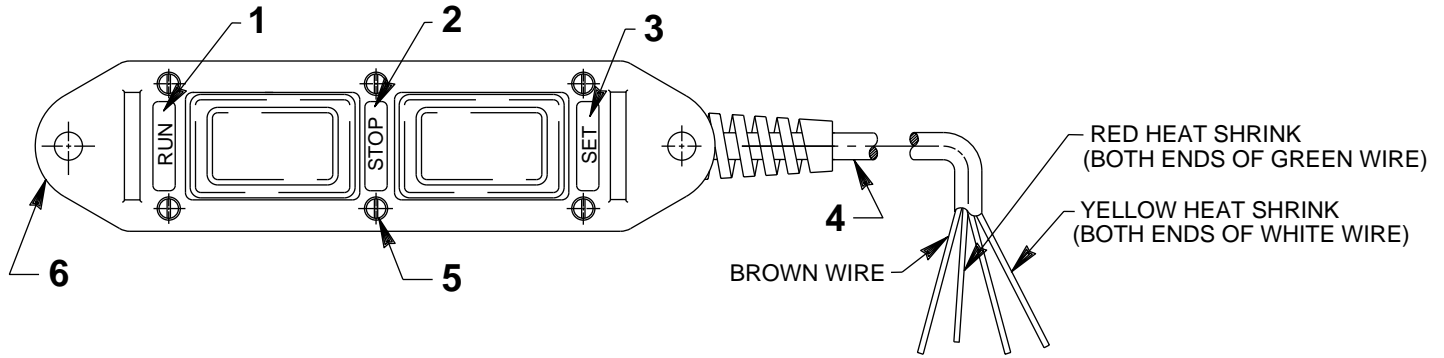

ROCKER SWITCH FUNCTION:
 OFF
 ON (CIRCUIT #1)
 ON (MOM) (CIRCUIT #1 & #2)

Item No.	Part No.	No. Req'd	Description
1	203770	1	Decal (Run)
2	203769	1	Decal (Stop)
3	252431	1	Decal (Set)
4	11391	21'	Cable (18/4 SJTO)
5	250248	6	Screw (4-24 X 3/4 Lg.)
6	251044	1	Plastic Cover
7	*420050-2	1	Gasket

Item No.	Part No.	No. Req'd	Description
8	*420017	1	Rocker Switch
9	253197	1	Push Button Switch
10	251802	1	Locknut
11	251818	1	Strain Relief Bushing
12	253607	1	Gasket
13	420050-4	1	Switch Housing
14	420050-5	1	Switch Mounting Plate

Part numbers marked with an asterisk (*) are contained in Maintenance Kit No. 090205.

**RECOMMENDED MINIMUM WIRE SIZE-AWG (mm²)
OF EXTENSION CORDS FOR
POWER TEAM ELECTRIC PUMPS**

Current At Full Load (Amps)	Cord Size AWG (mm ²) 3.2 Volt Drop			
	Length of Cord			
	0-25 feet (0-8 m)	25-50 feet (8-15 m)	50-100 feet (15-30 m)	100-150 feet (30-45 m)
6	18 (.82)	16 (1.33)	14 (2.09)	12 (3.32)
8	18 (.82)	16 (1.33)	12 (3.32)	10 (5.37)
10	18 (.82)	14 (2.09)	12 (3.32)	10 (5.37)
12	16 (1.33)	14 (2.09)	10 (5.37)	8 (8.37)
14	16 (1.33)	12 (3.32)	10 (5.37)	8 (8.37)
16	16 (1.33)	12 (3.32)	10 (5.37)	8 (8.37)
18	14 (2.09)	12 (3.32)	8 (8.37)	8 (8.37)
20	14 (2.09)	12 (3.32)	8 (8.37)	6 (13.30)
22	14 (2.09)	10 (5.37)	8 (8.37)	6 (13.30)
24	14 (2.09)	10 (5.37)	8 (8.37)	6 (13.30)
26	12 (3.32)	10 (5.37)	8 (8.37)	6 (13.30)
28	12 (3.32)	10 (5.37)	6 (13.30)	4 (21.29)
30	12 (3.32)	10 (5.37)	6 (13.30)	4 (21.29)